

1	Date	Revisions	Staff
	2020-12-16	螺芽孔变更	黄

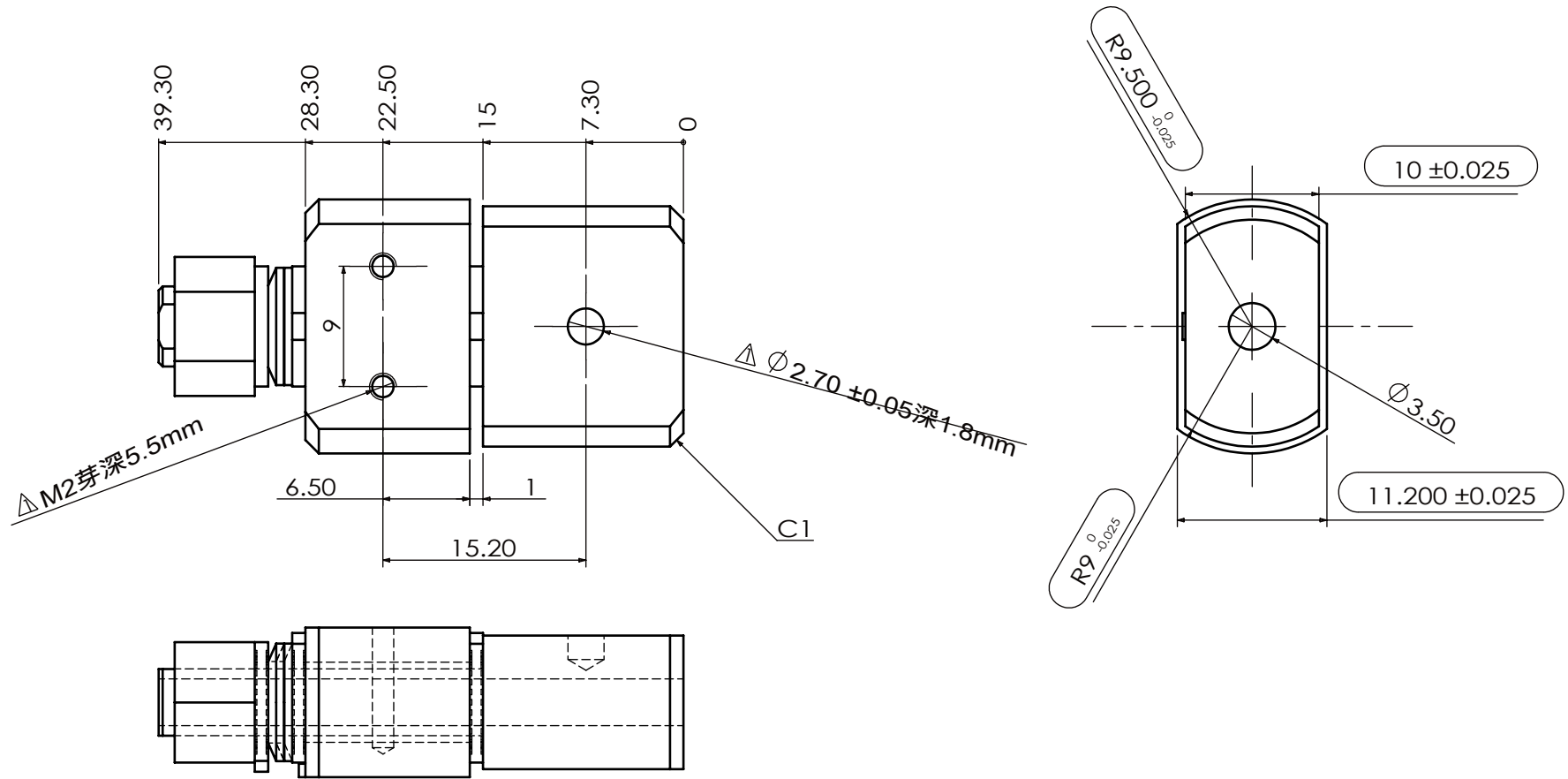

- 注:1.扭力 : 3kgf.cm
 2.寿命 : 1万回扭力变化+/-20%以内。
 3.带圆圈尺寸为重点尺寸。
 4.表面镀无化学镍3~6μm
 5.倒角均为:C0.5
 6.一般公差:+/-0.2。
 7.使用产品必须符合ROHS要求。

001	组装图				****	****	1	
No.	Parts Name				Materials	Treat	Q'ty	Remarks
Approved	Checked	Drawn	Designed	Date	Tolerance		Customer	
				2020.10.26	L < 1	0.05		
				Scale	Angle	1 ≤ L ≤ 4	0.1	DWG Name
				1:1	* °	4 < L ≤ 16	0.15	*****
Jiaxing yujia Machinery Co.,Ltd				Unit	mm	16 < L ≤ 63	0.2	DWG No.
					63 < L	0.25		SD2199A30001